

## BUS BAR FABRICATING TOOLS CUT / BEND / PUNCH

*Easy to Use Tools for All In-Plant & Site Work*

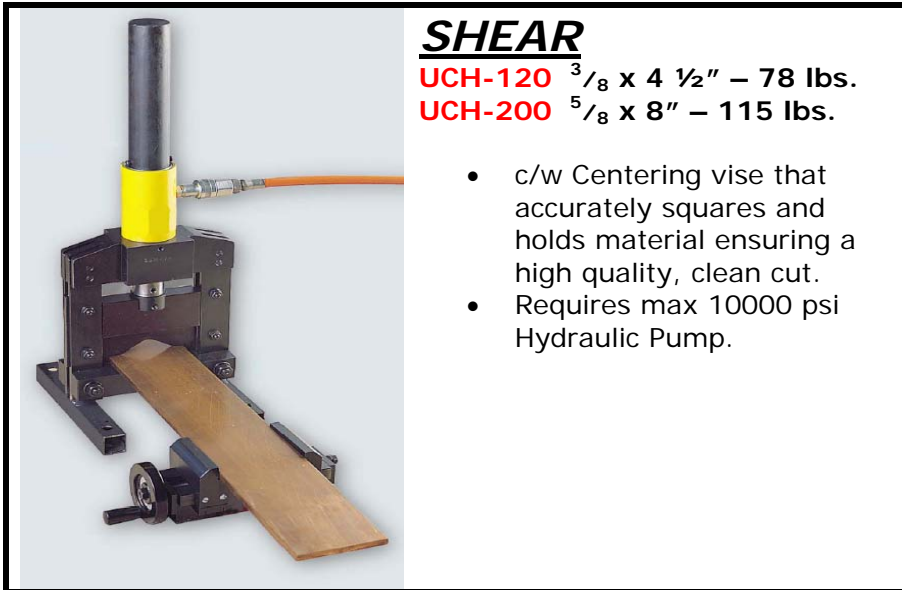

### **SHEAR**

**UCH-120**  $3/8$  x 4 1/2" – 78 lbs.

**UCH-200**  $5/8$  x 8" – 115 lbs.

- c/w Centering vise that accurately squares and holds material ensuring a high quality, clean cut.
- Requires max 10000 psi Hydraulic Pump.

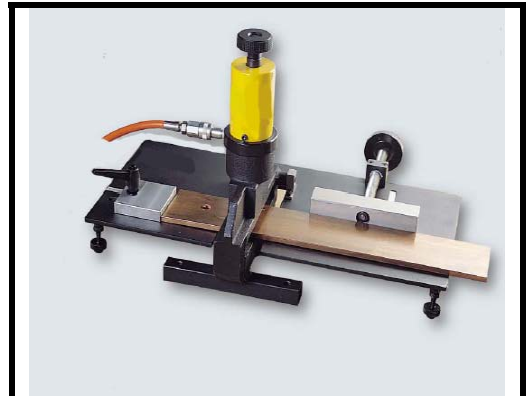

### **PUNCH**

**UPH-120**  $3/8$  x 4 1/2" – 54 lbs.

**UPH-200**  $5/8$  x 8" – 86 lbs.

- c/w Positioning slide base for exact movement of material in 'X' and 'Y' directions, with Scales.
- Allows for easy set up and production of various hole patterns.
- A full set of round punch/die sets are available.
- Requires max 10000 psi Hydraulic Pump.



- Manual or Electric Pumps Available
- Distributor valve allows operator to direct oil flow from one pump to up to three different work areas (not simultaneously).

**GENSCO EQUIPMENT**  
Across the U.S.A (800) 268-6797  
[info@genscoequip.com](mailto:info@genscoequip.com)  
(416)465-7521

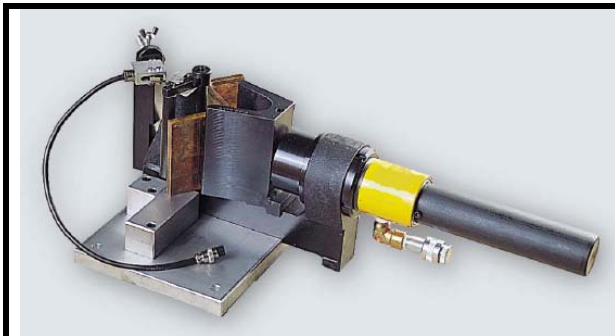

### **BENDER**

**UDH-120**  $3/8$  x 4 1/2" – 48 lbs.

**UDH-200**  $5/8$  x 8" – 110 lbs.

- c/w Electric limit switch for setting exact angle (max. 90°)
- Automatic Stop when angle is reached.
- Requires max 10000 psi Hydraulic Pump.